

WARNING

NORDIC ALUMINIUM LIGHTING TRACK SYSTEMS

DO NOT solder connectors as this will prohibit the adapters circuit switch to move freely from circuit to circuit.

Nordic Aluminium track adapters and accessories are made of strong polycarbonate material.

To clean, use only a damp cloth.

DO NOT expose to any lubricants, solvents or cleaning solutions, as they may impair the strength of the product.

Also, when changing the location of a fixture/adapter

DO NOT slide the adapter down the track as it will damage the connectors and cause faulty lighting.

Fixture must be taken out of track and placed to its desired location.

NORDIC  ALUMINIUM

Nordic Aluminium, Inc 4300C Bankers Circle, Doraville, GA 30360 Ph: 770-326-3331 Fax: 770-326-3353

GLOBAL *pro* series

3-circuit Lighting Track

INSTALLATION INSTRUCTIONS

IMPORTANT SAFETY INSTRUCTIONS

When installing or using this track system, basic safety precautions should always be followed, including the following :

1. Read all of these installation instructions before installing the GLOBAL pro lighting track system
2. Do not install the track in damp or wet locations.
3. Do not install any parts of the track system less than 5 ft above the floor.
4. Do not install any fixtures closer than six inches from combustible materials.
5. Do not install the track with electric power connected. Similarly, disconnect electricity when installing or removing fixtures or components or changing the configuration of the track.
6. Do not use this track with a power supply cord or convenience receptacle adapter.
7. The GLOBAL pro track system is intended for use only with GLOBAL pro components and fixtures marked for use with GLOBAL pro system. To reduce risk of fire and electric shock, do not use other components as part of this system.
8. Track installation is to only be performed by a certified electrician in accordance with the National Electrical Code and all local codes and ordinances.
9. Do not connect track to more than one branch circuit unless track is wired to either a 120/240 Volt single-phase three wire system, or to a 120/208 Volt 3-phase, 4-wire system. Check with a qualified electrician. Although the track lighting system may seem to operate acceptably, a dangerous overload of the neutral may occur and result in a risk of fire.
10. Do not attempt to energize anything other than Lighting Track Fixtures on the track. To reduce the risk of fire and electrical shock, do not attempt to connect power tools, extension cords, appliances and the like to the track.

SAVE THESE INSTRUCTIONS

INSTALLING AND REMOVING FIXTURES

To reduce the risk of fire and electric shock, use only fixtures marked for use with Nordic AluminiumXTS system

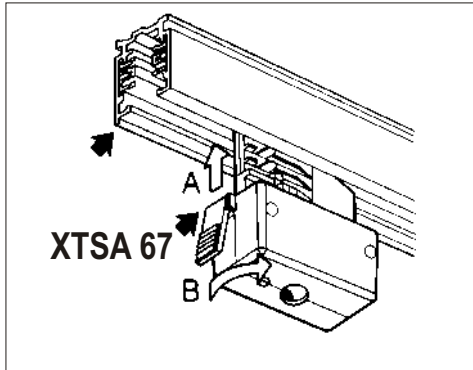

Fixtures with XTS 67 adapter are factory wired to circuit -1, -2 or -3 and can not be field modified. Fixtures must be returned to the manufacturer or distributor for modification of the circuit selection.

1. Align the fixture adapter so that the flange (ridge) on the track is on the same side as the locking knob of the adapter.
2. Insert the adapter into the track (A), turning it at the same time to the right (B) until the locking knob snaps into place behind the flange. **NOTE: ENSURE THAT THE ADAPTER IS TURNED ENOUGH THAT THE KNOB POSITIVELY SNAPS INTO PLACE OVER THE FLANGE.**
3. To remove the adapter, push the locking knob and pull the fixture assembly out, turning it to the left at the same time.

XTSA 68

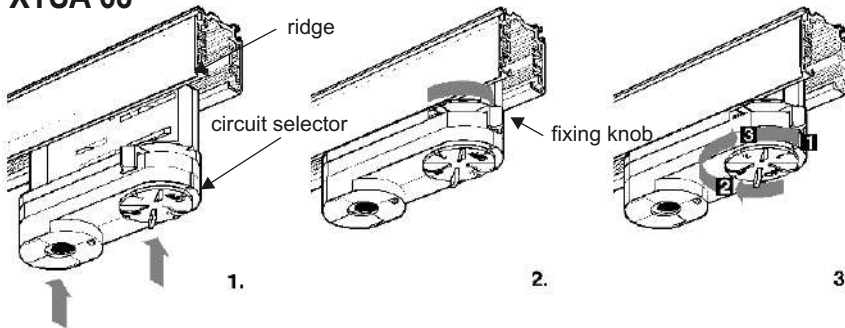

1. The fixture adapter is inserted with ridge opposite the track-ridge. Push the adapter into the track till it snaps into place.
2. Turn the mechanical fixing knob clockwise.
3. Select the desired circuit with the circuit selector knob.

To remove the adapter from track, select OFF-position before turning the mechanical fixing knob counterclockwise. Pull from fixing knob end.

ELECTRICAL CONNECTION

120 Volt
Single phase
Two wire

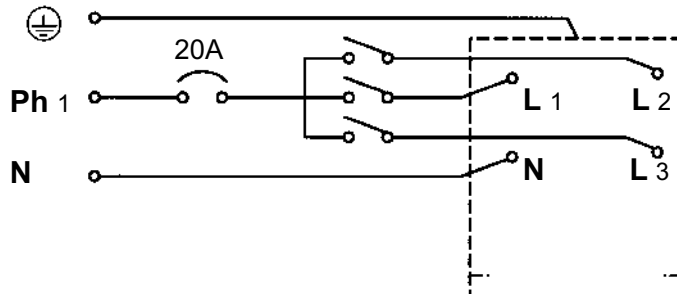

MAX LOAD: 2400 W

120/208 Volt
Single phase
Three wire

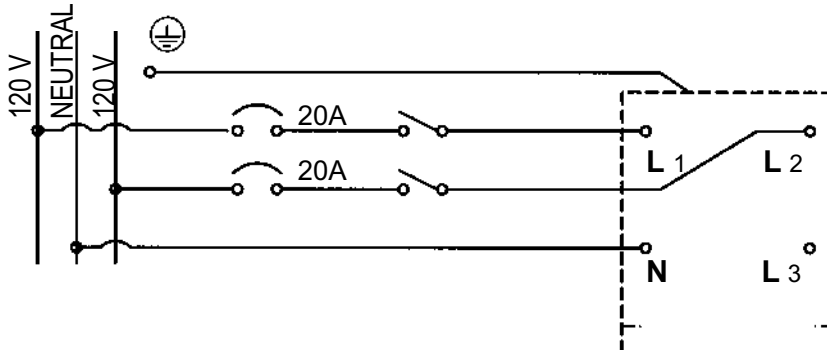

MAX LOAD: 4800 W
(EVENLY SPLIT BETWEEN CIRCUITS)

120/208 Volt
Three phase
Four wire

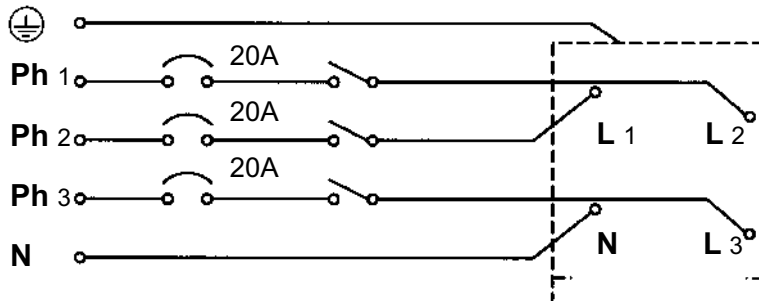

MAX LOAD: 7200 W
(EVENLY SPLIT BETWEEN CIRCUITS)

TERMINAL MARKING DEFINITIONS

L1 - Live Supply circuit 1

L2 - Live Supply circuit 2

L3 - Live Supply circuit 3

N - Neutral (Limited to 20A max)

⊕ - Ground

See diagrams above for connections to branch circuits

FEEDING TRACK AT A CORNER CONNECTOR

GLOBAL pro track can be fed at the following corners and track intercept connectors

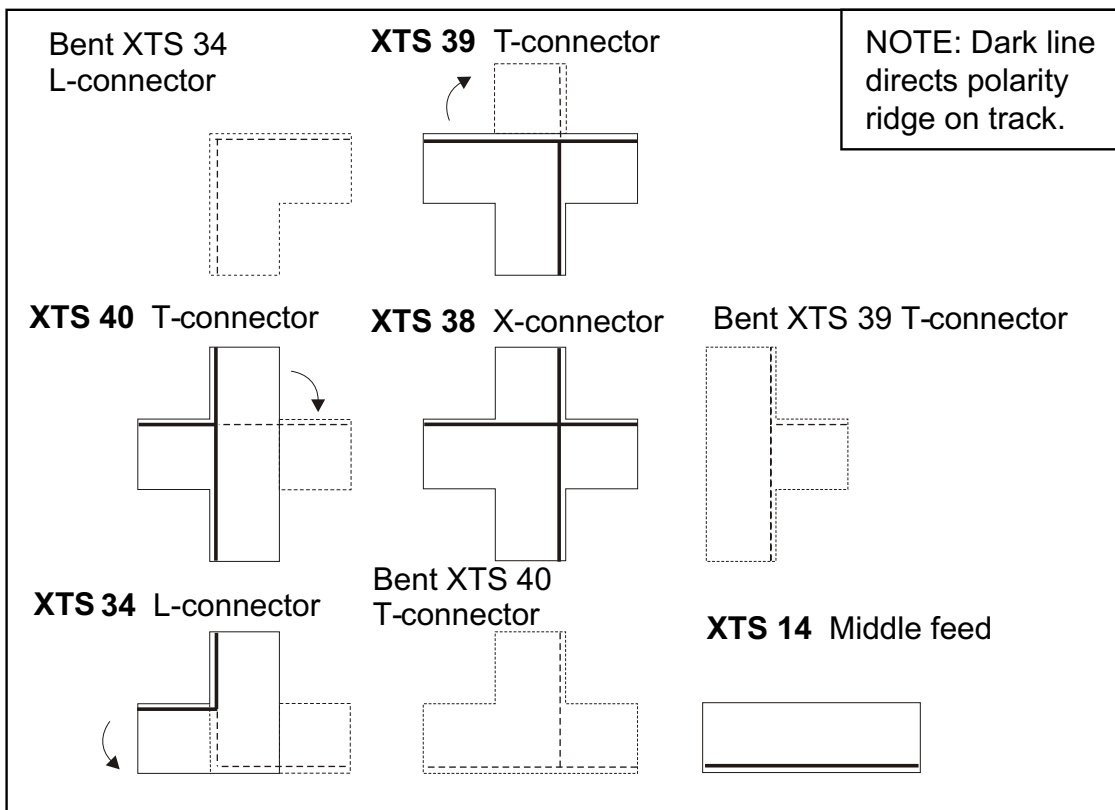

When feeding at one of the above connectors, follow the feeding instructions as shown under 'INSTALLATION OF GLOBAL PRO TRACK TO AN OUTLET BOX'.

NOTE: The track is polarized, so connectors can only be installed in the track in one direction. i, L, T, X-connectors are pre-wired, and should not be re-configured in the field. When requiring a turn in a different direction, or if an opposite T-connector is required, remove the cover and turn the connector as shown above.

XTS 21 Straight connector

INSTALLING CONNECTORS

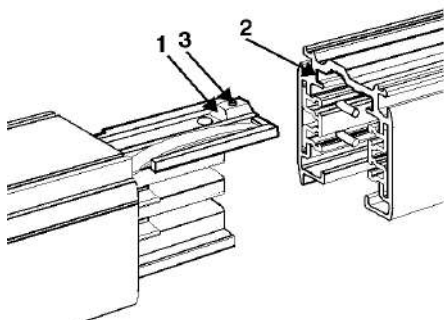

1. Select the correct connector to fit the end of the track.
2. Align the guide lug of the connector with the groove on the track.
3. Insert the connector into the end of the track, ensuring that the guide lug enters the groove in the base of the track.
4. If the connection is too tight, loosen the lock screw until the connector slides in.
5. Once the connector is correctly inserted, tighten the lock screw.

INSTALLATION OF GLOBAL PRO TRACK TO AN OUTLET BOX

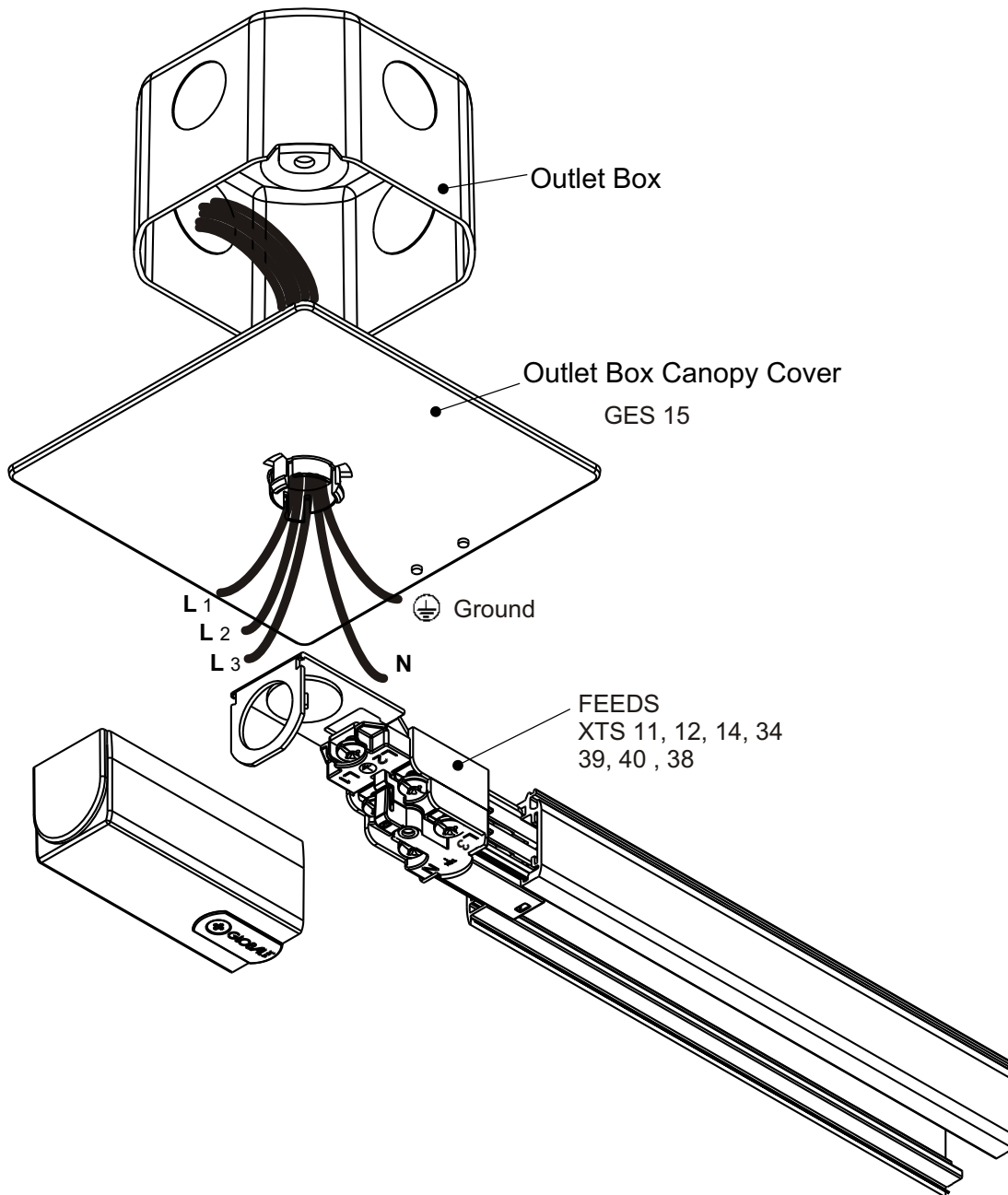

STEP 1.

Remove the knock-out hole provided on the back side of the feed connector. Remove feed connector cover.

STEP 2.

Pass the supply, neutral and ground wires through the canopy cover.

STEP 3.

Attach feed connector to track (NOTE: track is polarized and feed connector will only fit one end of track). Pass wires through hole on feed and mount track to ceiling using toggle bolts or screws.

STEP 4.

ALWAYS CONNECT GROUND WIRE TO GREEN GROUND TERMINAL. Connect live conductors to the appropriate terminal marked "L1", "L2" or "L3". Connect the neutral conductor to terminal marked "N".

STEP 5.

Replace feed connector cover plate

FIELD CUTTING OF TRACK TO LENGTH

The standard length XTS track is supplied with the conductor ends factory bent to allow for proper connection of fittings. However, the track can easily be field cut to different lengths with a hacksaw or a circular saw intended for cutting aluminum. After cutting, the conductor ends must be bent in the field with the Nordic XTSV 12 bending tool.

STEP 1

Carefully cut the track to length using a hacksaw or other metal saw. Ensure that the cut is clean and straight.

STEP 2

Insert the bending tool so that the track conductor fits in the outermost slot at the tip of the bending tool.

STEP 3

Rotate the bending tool 90 degrees upward. Repeat steps 2 and 3 for all four conductors.

STEP 4

Bent conductors should look similar to the factory finished ends, as shown.

STEP 5

Confirm correct bending by inserting the opposite end of the tool in the end of the track.

Bending tool

XTSV 12

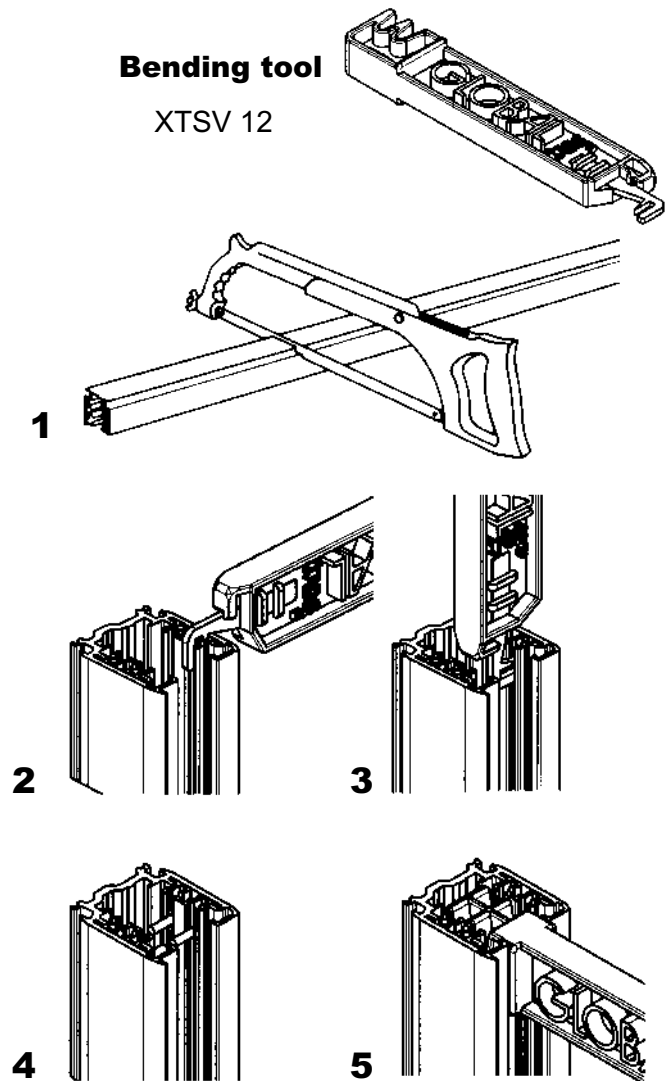

FIELD DRILLING OF MOUNTING HOLES

If track is field cut, it may become necessary to drill new mounting holes. If so, use one of the off-cut pieces with existing mounting hole as a template for new hole to be drilled. The drill bit should be no larger than $\frac{1}{4}$ inch in diameter. The hole should be centered in the groove in the bottom of the track. Remove burrs after drilling. Hole location should be in accordance with the note below.

NOTE: A single section of the track that is 4 feet or less in length must have one mounting opening spaced a **maximum of 6 inches** from each end of the track section. Additional openings may be provided. A single section of the track that is greater than 4 feet in length is to be provided with mounting openings spaced a maximum of 12 inches from each end of the track section with additional openings provided a minimum of every 4 feet along the length of the track section.

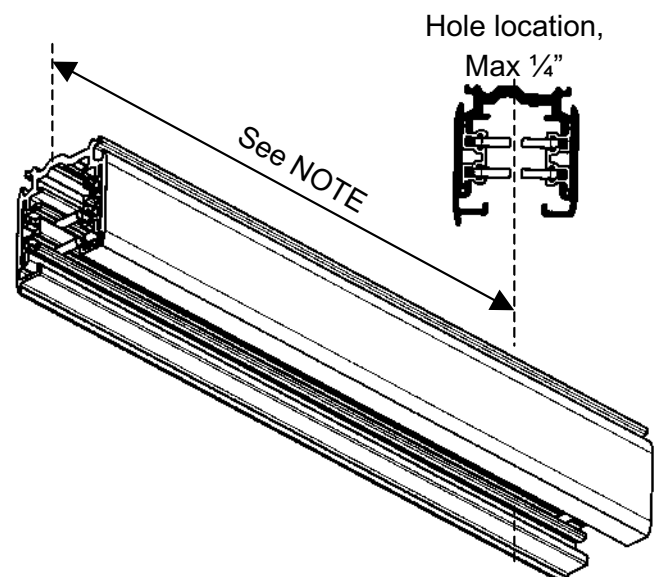

MOUNTING THE TRACK

NOTE: The track should be securely mounted at the maximum intervals of the 4ft, and must be mounted in accordance with all applicable codes and standards.

Ceiling mounting options

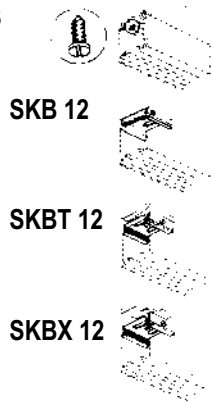

Instructions for each option:

- A. Using the factory provided mounting holes, use appropriate screw or toggle bolt for securing the track to the ceiling.
- B. Mark the location of the centerline of the track on the ceiling. Using an appropriate screw or toggle bolt, secure SKB mounting clips at the correct position on ceiling. Loosen the set screw on the side of the clips and insert the track, tightening the set screws while holding the track position.
- C. Use the SKBT 12 for securing the track to T-bar ceiling grids. Snap the clips onto the grid in the correct locations, then insert the track, tightening the set screws while holding the track in the position.
- D. Use the SKBX 12 for T-bar grid recessed into the ceiling tile. Follow the same procedure as C above.

Pendant Suspension

A. Pendant wiring detail

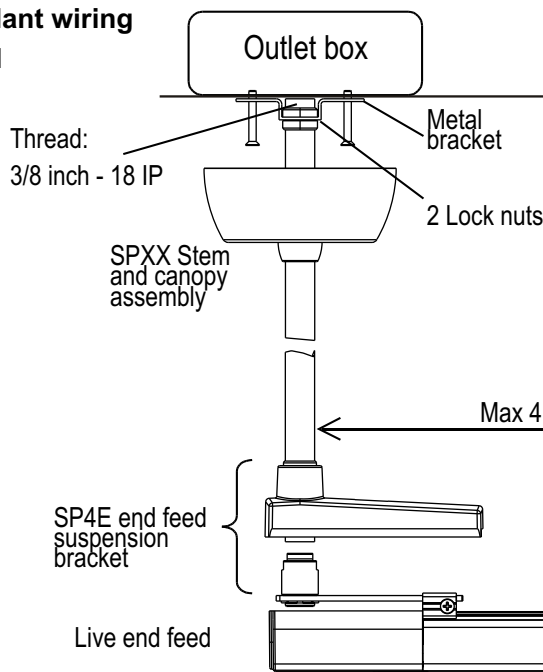

B. Mechanical pendant support detail

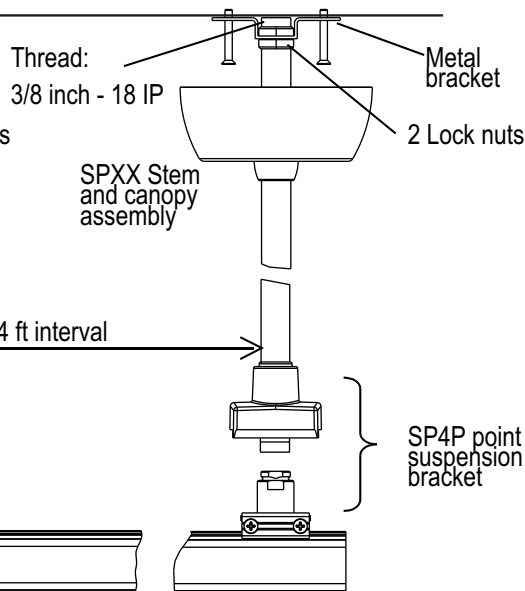

Electrical feed through pendant feed stem, Catalog numbers SP XX.

1. Secure mounting bracket to outlet box using hardware provided.
2. Thread one nut on upper end of feed stem. Pass required supply wires and ground wire (by others) through second nut and through feed stem. Attach upper threaded portion of stem to mounting bracket and secure second nut tightly.
3. Loosen lock screw and slide canopy up stem, taking care not to scratch the surface finish. Tighten canopy once in position.
4. Remove plastic cover from SP 4E mounting bracket. Using a sharp knife, cut out the top protrusion to allow the feed stem to pass through cover. Slide cover up stem while completing remaining connections.
5. Pass supply and ground wires through metal bushing of SP 4E mounting bracket. Thread bracket onto stem and tighten.
6. Cut out knock-out on back side of live end feed connector using a sharp knife. Pass wires from the mounting bracket through the knock-out and attach live end to track.
7. Secure mounting bracket to back of track, fastening the set screws.
8. Attach supply leads and ground wire to proper screw terminals in the live end and replace the cover.
9. Slide mounting bracket cover down the stem and over the mounting bracket.

Track support using pendant stem, Catalog numbers SP XX.

1. Secure mounting bracket to outlet box using hardware provided or other appropriate fasteners.
2. Thread one nut on upper end of feed stem. Attach upper threaded portion of stem to mounting bracket and secure second nut tightly.
3. Loosen lock screw and slide canopy up stem, taking care not to scratch the surface finish. Tighten canopy once in position.
4. Remove plastic cover from SP 4P mounting bracket. Using a sharp knife, cut out the top protrusion to allow the feed stem to pass through cover. Slide cover up stem while completing remaining connections.
5. Thread SP4P metal bracket onto stem and tighten.
6. Secure mounting bracket to back of track, fastening the set screws.
7. Slide mounting bracket cover down the stem and over the mounting bracket.

(XX = Stem length in inches)